

For latest developments,
please have a look at ↘

www.celsius.nl

screw heat exchangers

°Celsius

screw heat exchangers

°Celsius



Lipsstraat 42
P.O. Box 168
5150 AD Drunen
The Netherlands

T +31(0)416 38 22 92
F +31(0)416 37 83 50
info@celsius.nl
www.celsius.nl

Science, knowledge and trust

With your ideas...



...and our knowledge and professional expertise...

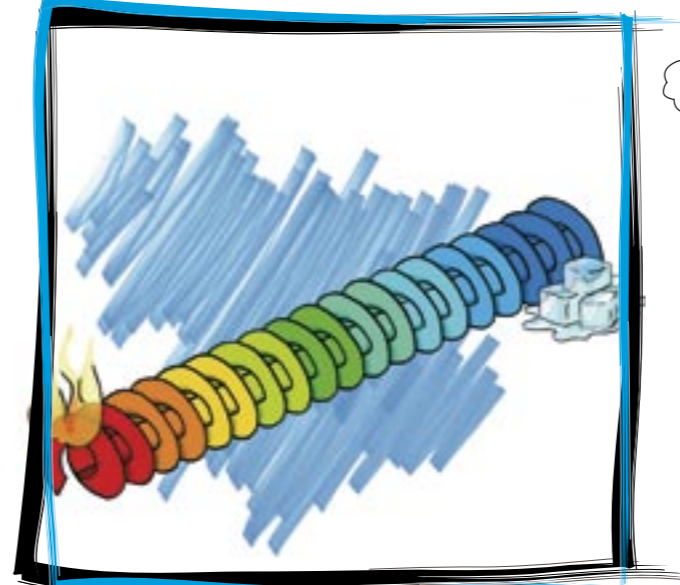

°Celsius supplies tailor-made solutions. The technical execution of an °Celsius project can only be determined after tests have been carried out at the test centre with the product that is to be treated. The strength of °Celsius lies in offering the complete process, from input material to the final product. We guarantee processes on the basis of tests, calculations, engineering and experience.

If the client wants it that way, °Celsius takes a leading role for the duration of the whole project and makes sure things happen! Whether it involves the heating (or cooling) system that is to be used, insulation, feed-in and discharge of the product, humidity measurements or process control.

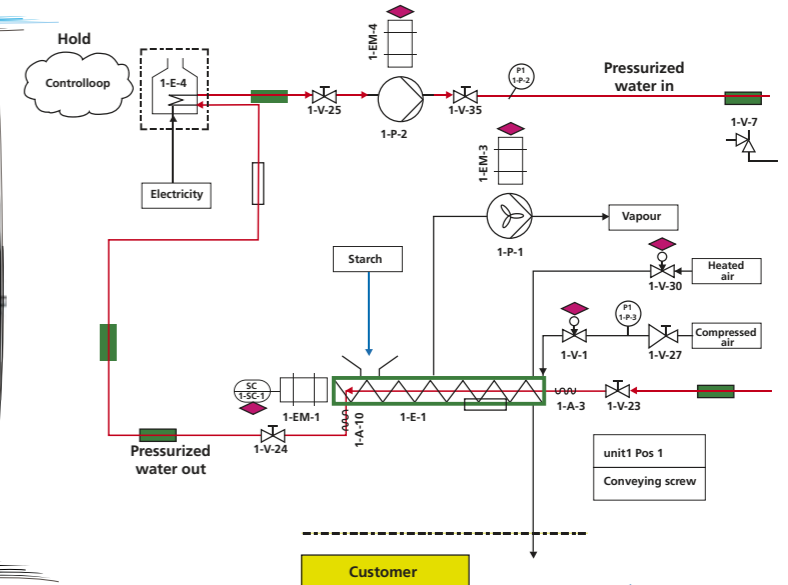

...your application will fit like a glove.

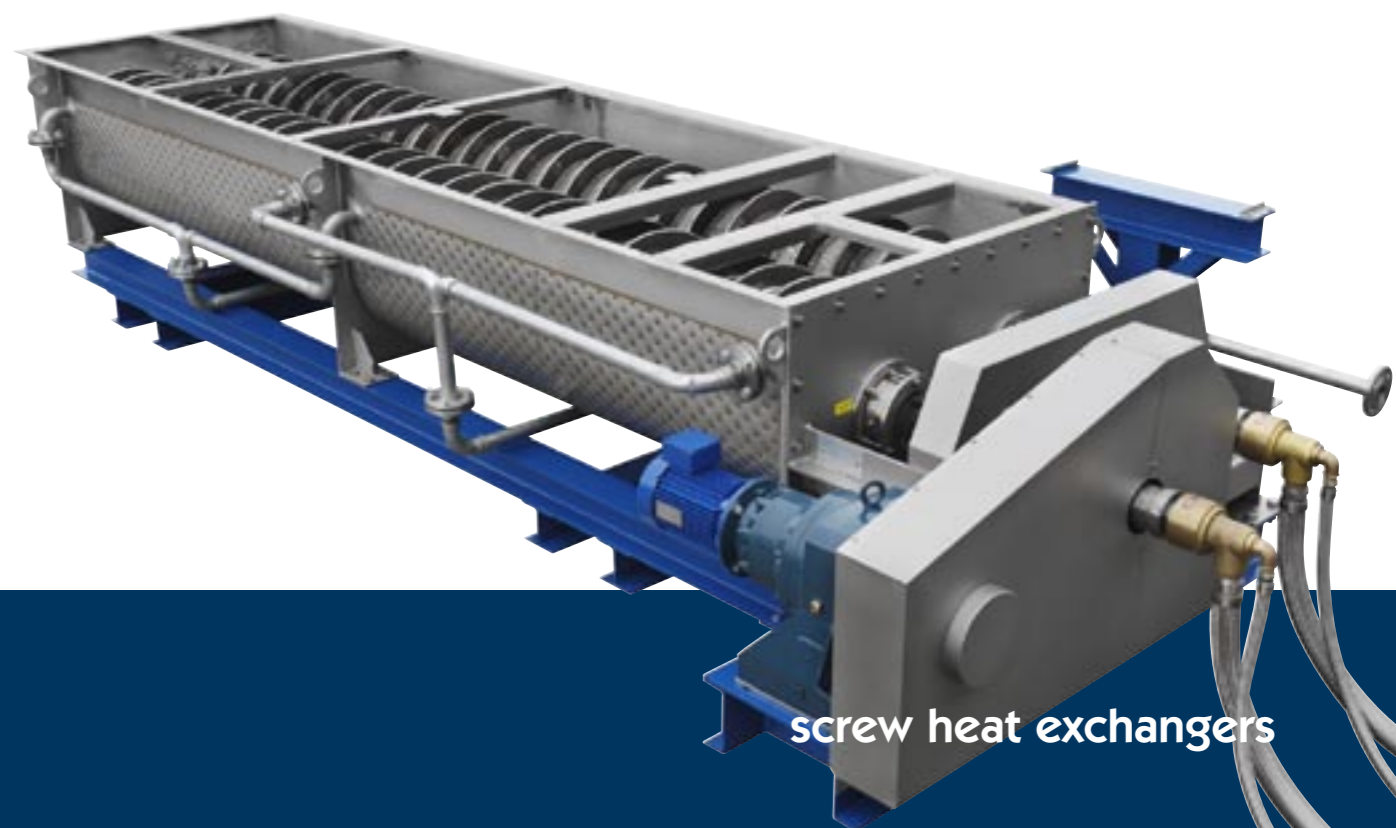
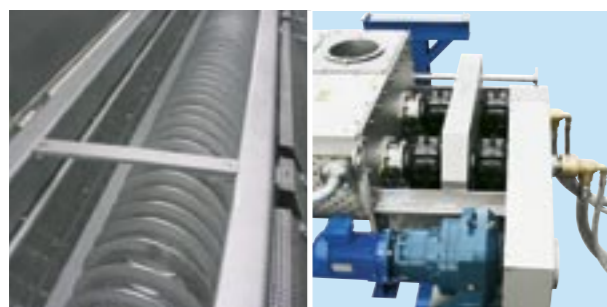

Warming up or cooling down

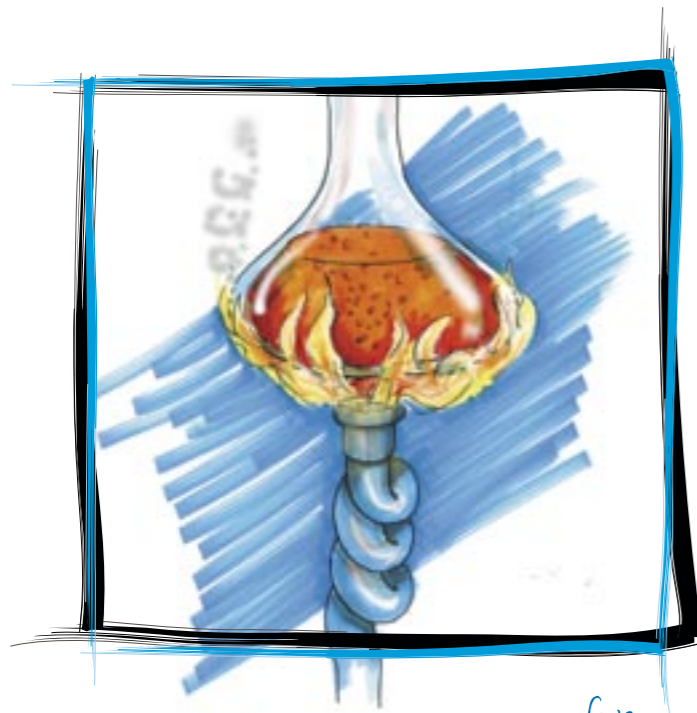

Warming up for
sterilisation, pasteurisation,
drying, fusing...



...cooling down to prevent
condensation...



...can be applied
much more often
than you think.

°Celsius applications are used to effect changes in the temperature of the product while it is being moved. This can be either by cooling or heating the product. There can be a number of different reasons for wanting to achieve this effect, for instance:

- product cooling for a subsequent production process
- product cooling for packaging or storage
- heating to sterilise or pasteurise
- to achieve certain chemical reactions

(fusing, 'popping', mixing, solidifying, drying, etc). Screw heat exchangers are heated or cooled by allowing a fluid to flow between the inner and outer skins of the conveyor. The jacket applies to the trough wall and the screw axes and often the screw blades as well. For efficient thermal transference, it's not just having heat transfer surface that is important, but the length of residence time is also essential.



Tailor-made applications of all kinds

From Eggshell drying...

...to Thermomixing

°Celsius applications are always tailored to the client's specific needs and are used for a large variety of products. However, °Celsius has developed an application template for two particular applications, namely: **Eggshell drying** and **Thermomixing** (for heating and simultaneously mixing all sorts of food components with a binder).

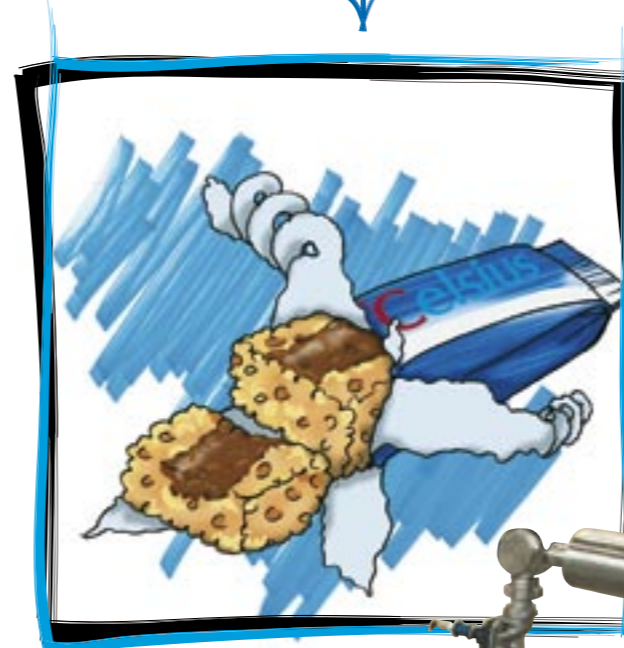

°Celsius has a comprehensively equipped test centre. This test centre can be used by clients to test the properties of the product that they want to use. During such tests, you will be assisted by an experienced expert in the area of thermal processing. The test centre offers standard a thermal unit, dosage installation and two twin screw heat exchangers one heated with oil and the other with hot water.



°Celsius, number one in screw heat exchangers.

